



What's New with VMware vCloud® Director™ 5.1

Feature Overview

TECHNICAL WHITE PAPER
JULY 2012

Table of Contents

What's New with VMware vCloud Director 5.1..... 3

- Software-Defined IaaS.....3
 - Hardware and OS Support3
 - Software-Defined Storage3
 - Software-Defined Networking4
 - Elastic Virtual Datacenter5
- Ease of Consumption.....6
 - Usability6
 - Snapshots.....6
 - Metadata6
- Security and Control.....7
 - Single Sign-On7
 - vCloud Networking and Security Gateway Services.....7
 - Load Balancer7
 - VPN8
 - NAT.....8
 - DHCP.....8
 - Firewall8
- Next Steps.....8
 - Additional Documentation.....8
 - VMware Contact Information8
 - Providing Feedback.....8

What's New with VMware vCloud Director 5.1

VMware vCloud® Director™ (vCloud Director) orchestrates the provisioning of software-defined datacenter services, to deliver complete virtual datacenters for easy consumption in minutes. Software-defined datacenter services and virtual datacenters fundamentally simplify infrastructure provisioning and enable IT to move at the speed of business.

Numerous enhancements are included within vCloud Director 5.1, making it the best infrastructure-as-a-service (IaaS) solution in the marketplace today. This document highlights some of these key enhancements and is targeted toward users who are familiar with previous vCloud Director releases.

Software-Defined IaaS

Just as the virtual machine is the virtualized compute container that has been the hallmark of the virtualization decade, the virtual datacenter is a new logical container that provides all infrastructure services, including virtualized networking, storage and security.

Hardware and OS Support

Support of an IaaS environment begins at the hardware layer. At the forefront of technology, vCloud Director now supports VMware vSphere® 5.1 (vSphere 5.1) virtual hardware version 9 and all the features it provides, such as support for 64 virtual CPUs and 1TB of memory for virtual machines.

A key feature of virtual hardware version 9 is support for Intel VT-x/EPT and AMD-V/RVI technologies. Leveraging the hardware-assisted CPU virtualization capabilities of these technologies enables more efficient execution of the hypervisor.

Enabling hardware-assisted CPU virtualization increases the amount of memory overhead and restricts the use of VMware vSphere® vMotion® (vMotion) to hosts that support this technology. This is an important consideration for ensuring continued capability within the environment.

Guest operating system (OS) support also has been increased to include Microsoft Windows 8 and MAC OS versions 10.5, 10.6, and 10.7.

Software-Defined Storage

Not all storage in an environment is the same. Storage systems range from very high speed and low latency to very slow speed and high latency. Typically, increases in performance require a corresponding increase in price. Using metrics such as these, system administrators strive to optimize the storage provided to users in such a way as to provide the best storage services at the least cost to the organization.

VMware vSphere 5.0 (vSphere 5.0) introduced storage profiles, which enabled users to map the capabilities of a storage system to a storage profile. By selecting the storage profile matching their requirements, users could ensure that the virtual machines they created utilized an appropriate datastore.

Storage profiles, now in vCloud Director 5.1, are available to cloud administrators, enabling them to offer multiple tiers of storage within a single virtual datacenter. For example, a cloud administrator can create storage profiles identifying three different storage tiers—gold, silver and bronze. These storage profiles represent the capabilities of the given storage. After the storage profiles have been created, a single primary virtual datacenter can consume all of them. The cloud administrator then can present all or a portion of the storage tiers to a given organization. The organization administrator can define a default storage tier to be used when organization vApp authors create vApps. The vApp author can override the default storage tier as needed. This enables the vApp author building a typical three-tier application to provide gold-tier storage to a database while providing silver-tier storage for the Web and middleware.

Storage profiles also are integrated with VMware vSphere® Storage vMotion® (Storage vMotion) and VMware vSphere Storage DRS™ (Storage DRS). This enables the automatic relocation of workloads to storage matching the requirements specified by the storage profile.

vApp templates, media and independent disks also support the use of storage profiles. In the case of vApp templates, a default instantiation storage profile also can be defined, to designate the storage tier to be used, if available, when the vApp template is deployed.

Software-Defined Networking

Providing IaaS services involves more than providing just compute and storage. It also involves providing agile networking capabilities and services that are easy to consume. To enable this, the vCloud Director 5.1 release incorporates a series of enhancements involving networking.

Prior releases of vCloud Director provided a model of networking for an organization in which the networking was separated from the organization and required a VMware vCloud® Networking and Security (VCNS) Gateway (previously known as the VMware® vShield Edge™ Gateway) for each network. In vCloud Director 5.1, this organization network model has been replaced with an Organization vDC (Org vDC) network model. Org vDC networks tie the network resources to the organization. This greatly simplifies the deployment and configuration of the network, enabling the network to be deployed as part of the organization. Networks continue to have the ability to connect multiple organizations through the use of a shared Org vDC network.

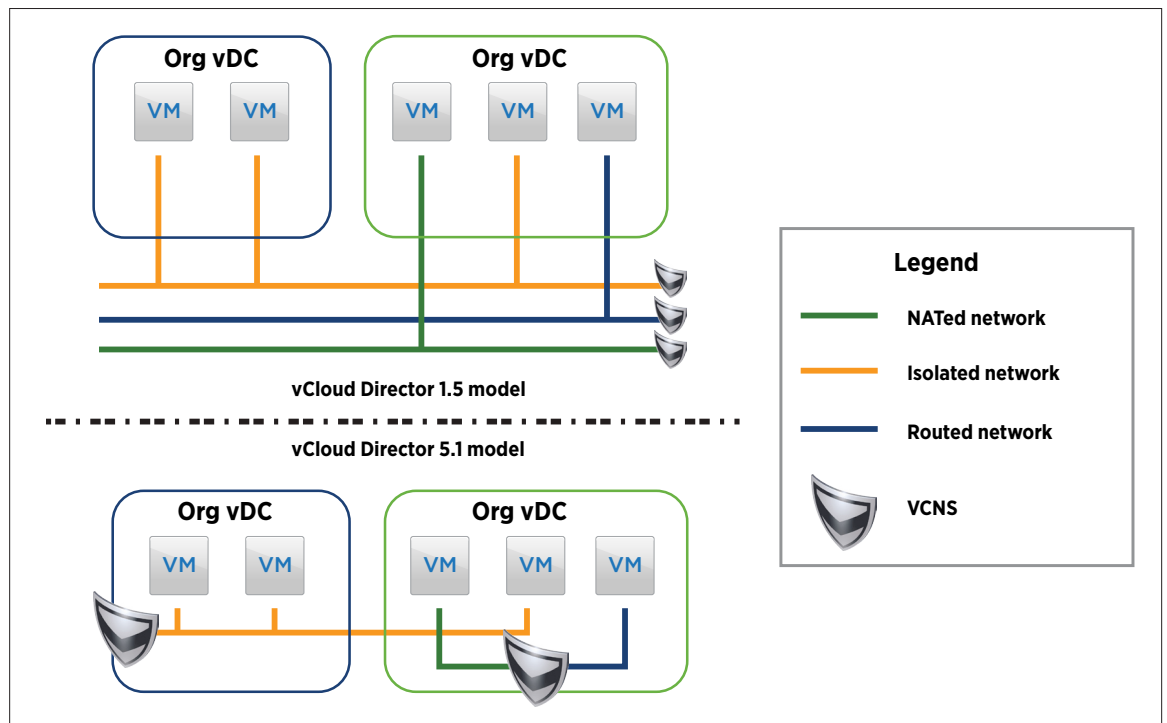

Figure 1. Contrast in Network Models Used in vCloud Director 1.5 (Organization Network) and vCloud Director 5.1 (Organization vDC Network)

Building on the association of an Org vDC network to an organization, an integrated Org vDC workflow has been introduced. Compute, storage and networking now can be created in a single workflow, enabling administrators to deploy a complete infrastructure in minutes.

In previous releases, the VCNS Gateway that provided network services and security was not visible to the user. Now, the VCNS Gateway is a first-class entity in vCloud Director and is accessible through the vCloud Director user interface.

The capabilities of the VCNS Gateway have also been enhanced. A VCNS Gateway now provides multiple interfaces to an external network. Each of these interfaces enables an IP address to be assigned to them for external network connectivity. Rate control is configurable on the external interfaces as well, enabling the throttling of both inbound and outbound traffic.

Administrators now can assign noncontiguous blocks of IP addresses to the organizations using the cloud services. This enables the cloud administrator to assign a block of IP addresses when an organization initially is deployed. If the organization's resource use grows, requiring additional IP addresses, another block of IP addresses can be assigned to the organization. This capability, in addition to the ability to assign multiple subnets to an external network, gives the cloud administrator increased agility to grow with demand.

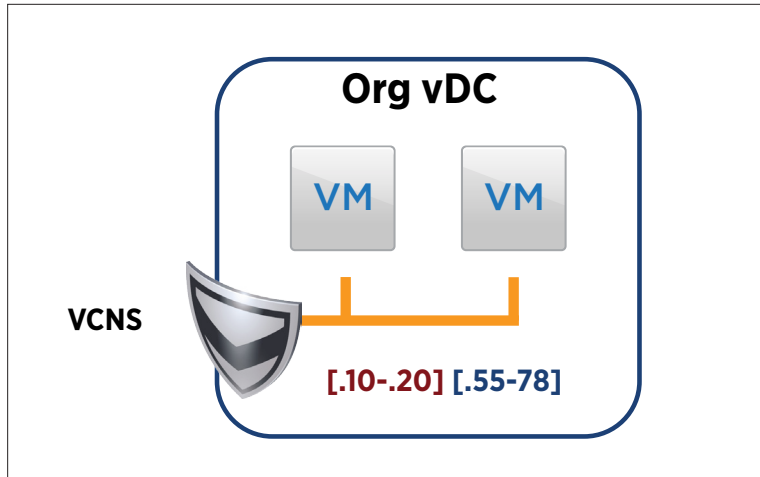

Figure 2. Noncontiguous Blocks of IP Addresses Now Can Be Assigned to an Organization (The first block of IP addresses, shown in red, was assigned to the organization initially. The second block of IP addresses, shown in blue, was assigned as a result of organizational growth.)

Availability of the VCNS Gateway device has been increased through the introduction of a high-availability feature. This enables a secondary VCNS Gateway to be deployed to provide fully stateful failover of services in the event of a failure of the primary VCNS Gateway.

Two different VCNS Gateway deployment models are now offered: “compact” and “full.” The full version can achieve a higher throughput than the compact version and is on par with similar mid- to high-range physical devices in the marketplace today. Providing this increased performance consumes additional resources and might not be required in all environments. Users are free to choose the model appropriate to their environment and even to upgrade from the compact to the full model if higher performance becomes required.

Now the VCNS Gateway can function as a DNS relay as well. This feature enables a vApp author to point all the virtual machines within a vApp to the VCNS Gateway for DNS resolution. The VCNS Gateway sends responses to DNS queries back to the virtual machines after acquiring the information from the DNS servers of the external network. Because this provides a layer of abstraction between the external network and the virtual machines within a vApp, the virtual machines are unaffected by changes to the external network that impact DNS resolution.

Elastic Virtual Datacenter

In vCloud Director 1.5, the concept of Elastic Virtual Datacenter (Elastic vDC) was introduced for use with the pay-as-you-go (PAYG) resource allocation model. Elastic vDCs enabled a Provider vDC to utilize more than one single resource pool or cluster. Today, vCloud Director 5.1 extends this concept to the allocation pool resource model. This provides a container that can grow automatically, without manual intervention by the cloud administrator, in response to organization requests. Intelligent placement methods utilized by vCloud Director ensure that administrators must not necessarily concern themselves with which cluster or resource pool is best suited to host a given workload.

Coupled with the capabilities of VXLAN to provide a stretched L2 domain, vCloud Director can consume resources from different resource pools, regardless of the physical network configuration. This capability provides a seemingly endless supply of resources that can be consumed.

In previous versions of vCloud Director, Elastic vDCs were restricted for use with the PAYG allocation model. Due to this, customers resorted to assigning multiple Provider vDCs to offer the same functionality with other allocation models. A feature has been added now that enables a cloud administrator to consolidate two Provider vDCs into a single one to obtain the optimal utilization of resources.

Although vCloud Director provides an automatic placement engine that intelligently manages the deployment of workloads, there are times when the manual rebalancing of virtual machines across Provider vDC resource pools is preferable. This includes scenarios where an administrator decommissions an existing resource pool or adds a new resource pool. For such scenarios, a feature has been included that enables the migration of virtual machines utilizing a shared datastore. Administrators can choose to migrate a virtual machine to a specific location or to leverage the vCloud Director placement engine to relocate the virtual machine to a suitable location automatically.

Ease of Consumption

For maximum effectiveness, in addition to having all the tools required for deploying IaaS services, the solution must be simple to use. It also must include all the services and functionality required for proper operation. vCloud Director provides this, enabling users to deploy complete solutions within minutes.

Usability

Enhancing the user experience is of paramount concern to VMware. With the vCloud Director 5.1 release, several usability enhancements were made, including the following:

- The enhanced "Add vApp from Catalog" wizard makes it easier to quickly locate gold master templates, visualize the remaining virtual machine quota available, and access important information about the vApps and the virtual datacenters. This wizard also has been streamlined by providing more defaults for commonly accepted features.
- It provides easy access to virtual machine quota and lease expirations.
- A redesigned catalog navigation and subentity hierarchy now enables each catalog to have its own set of navigational history, with automatic refreshes of data to provide the most up-to-date information.
- Help and documentation links now are provided throughout the user interface, enabling users to directly access the latest information from vmware.com.

Snapshots

As a consumer of a cloud, a user often finds it helpful to be able to revert back to how the environment was at a particular point in time. Reverting to a baseline configuration, recovering from a failed patch attempt, and supporting testing or training evolutions are all examples of instances when this would be wanted.

To provide this functionality, vCloud Director 5.1 now is able to take a snapshot of a single virtual machine or an entire vApp. After a snapshot has been taken, a user easily can revert to that point in time when it was taken.

Metadata

With the ease of consumption, there arises a need to be able to manage and report on the objects within the cloud environment. In vCloud Director 1.5, users were able to employ the vCloud API to add metadata consisting of name-value pairs to entities within vCloud Director. They then were able to access this information programmatically to assist in the creation of scripts for reporting or other purposes.

In vCloud Director 5.1, the ability to view and manage metadata is provided within the vCloud Director user interface. Users with the appropriate level of access can view, add, modify and delete metadata as necessary. Of course, it still is possible to use the vCloud API to employ the metadata information.

Security and Control

An infrastructure does not stand alone and is only as powerful as the services that it enables. vCloud Director provides all the services a user requires to create a dynamic and secure IaaS environment.

Single Sign-On

Maintaining secure access to cloud resources is of paramount concern to any organization. Multiple layers of security tend to get introduced into an organization as new products and services are deployed. With so many security layers, users easily can become confused attempting to remember which portal to log in to and when to use a particular password. The more cumbersome the security policies are for the users, the more apt users are to attempt to bypass them.

To assist in providing a manageable, secure cloud environment, VMware now has incorporated a single sign-on (SSO) capability with vCloud Director. This provides several advantages to users and security managers.

ROLE	ADVANTAGES
Security Managers	<ul style="list-style-type: none"> • Dictate standardized access control policies. • Easily perform auditing for compliance. • Manage users from a central location. • Increase security.
Users	<ul style="list-style-type: none"> • Have one password for the entire environment. • Log in once and access many times. • Get faster access-problem resolution.

Table 1.

How SSO is used largely depends on the role of the user within the cloud environment. Consumers of the cloud tend to use the Web-based SSO feature, whereas cloud providers are likely to also leverage the Microsoft Windows Security Support Provider Interface (SSPI) support.

Administrators can leverage the SAML 2.0 standard that is supported with vCloud Director 5.1 to integrate vCloud Director with a number of Intrusion Detection and Prevention (IDP) solutions, including Active Directory Federation Services (ADFS) and OpenSSO.

vCloud Networking and Security Gateway Services

A fully functional infrastructure depends on a variety of network services. Out of the box, vCloud Director provides a set of commonly used network services for use with an IaaS implementation. The following services are provided through the use of the VCNS Gateway:

Load Balancer

The VCNS Gateway now offers a robust load balancer integrated with the vCloud Director user interface. This load balancer provides a virtual server that performs load balancing to a pool of servers supplying a specific service.

Configuring a pool begins by defining the services to be load balanced and the service port used by the members of the pool. The user can select a combination of HTTP, HTTPS and TCP services. Each service can utilize a different load balancing algorithm to provide for the greatest flexibility. The selectable load balancing algorithms include round-robin, URI, and Least Connected.

Each configured service provides a method to check the health of the service. Individual health-check intervals and timeouts can be defined. Health checks also can be configured to utilize a port different from the one used by the service, to avoid any impact on the service.

As members of the pool are added, the user is able to define a weight value for each member, to specify the balance among the pool members. This enables certain members to be favored over others for the load-balanced traffic.

The virtual server provides several means of maintaining persistence, based on the protocol used. For example, persistence might involve the use of cookies for HTTP traffic or a session ID for HTTPS traffic.

VPN

As previously mentioned, enhancements to the VCNS Gateway enable improved functionality in other features. For example, because the VCNS Gateway now supports multiple external network interfaces, the VPN service now enables a public IP to be defined for each interface. For another example, now that the VCNS Gateway supports multiple subnets, the VPN service supports the use of multiple subnets for participation in the VPN tunnel. The VPN service itself was enhanced to enable the specification of multiple remote peer networks as well as the addition of AES-256 encryption support.

NAT

The network address translation (NAT) service has been changed to enable the specification of both Source NAT (SNAT) and Destination NAT (DNAT) rules. These rules can be selectively applied to a given VCNS Gateway interface. Rules now support the ICMP protocol and can be configured using an individual IP, a range of IPs or a CIDR block.

DHCP

Similar to other networking services, the DHCP service provided now enables multiple IP address ranges to be assigned. It also enables the user to specify the internal Org vDC network to be used for the DHCP range.

Firewall

Firewall rules now can be applied to a specific VCNS Gateway interface. The rules also enable the use of an individual IP, a range of IPs or a CIDR block when creating the IPs.

Next Steps

Additional Documentation

For more information about VMware vCloud Director, visit the product pages at:
<http://www.vmware.com/products/vcloud-director/overview.html>.

You can access the documentation for vCloud Director by going to:
http://www.vmware.com/support/pubs/vcd_pubs.html.

VMware Contact Information

For additional information or to purchase VMware vCloud Director, the VMware global network of solutions providers is ready to assist. If you would like to contact VMware directly, you can reach a sales representative at 1-877-4VMWARE (650-475-5000 outside North America) or email sales@vmware.com. When emailing, include the state, country and company name from which you are inquiring.

Providing Feedback

VMware appreciates your feedback on the material included in this guide. In particular, we would be grateful for any guidance on the following topics:

1. How useful was the information in this guide?
2. What other specific topics would you like to see covered?

Please send your feedback to tmfeedback@vmware.com, with "What's New with vCloud Director 5.1" in the subject line. Thank you for your help in making this guide a valuable resource.

